

## GLOBAL JOURNAL OF ENGINEERING SCIENCE AND RESEARCHES

### A NOVEL BACK TO BACK GRID CONNECTED HYBRID PHOTOVOLTAIC/WIND SYSTEM

P.L. Santosh Kumar Reddy<sup>1</sup> & B.Pangedaiah<sup>2</sup>

<sup>1</sup>PG Scholar, EEE, lakireddyBalireddy College of Engineering

<sup>2</sup>Asst.Professor, EEE, lakireddyBalireddy College of Engineering

#### ABSTRACT

A new topology of a hybrid distributed generator based on photovoltaic and wind-driven permanent magnet synchronous generator is proposed. The PV array is directly tied to the DC link without any power converter providing variable DC-link voltage. The Perturb and Observe technique extracts the maximum power from PV and the DC-link voltage is set to the maximum power point (MPP) voltage of the PV array. The output DC voltage of WSC is regulated to an MPP PV voltage. Maximum power from the PMSG is extracted using optimal torque control and generate reference current for the wind side converter (WSC). Grid side converter (GSC) tracks the maximum power from wind and PV array using vector control, and serves as a shunt active power filter to compensate for the current unbalance due to the connection of non-linear loads at the grid. All these functions are accomplished simultaneously. Various power transfer modes of operation are simulated through MATLAB/Simulink.

**Keywords:** Hybrid systems, Grid connected systems, Distributed Generation systems.

#### I. INTRODUCTION

Due to the fact that environmental concerns have constrained the use of polluted energy resources for electric power generation, the interest in looking for possible alternatives concerning clean and renewable energy sources is growing worldwide. The increasing number of renewable energy sources and distributed generators requires new control strategies for the operation and improve the efficiency and quality [1-2]. In recent years, the wind and photovoltaic generation technologies have brought opportunities for electric power generation. DG (Distributed Generation) systems based on a single intermittent source, either photovoltaic (PV) or wind energy system, are unreliable due to seasonal variations. DG systems consisting of two or more renewable sources have a higher reliability due to the complementary nature of the resources [3-4]. Generally doubly feed induction generators (DFIGs) are widely used as the generator in a variable speed wind turbine system. In case of DFIG, there is a requirement of the gearbox to match the turbine and rotor speed. The gearbox many times suffers from faults and requires regular maintenance [5], making the system unreliable. The reliability of the variable speed wind turbine can be improved significantly using a direct drive-based permanent magnet synchronous generator (PMSG). PMSG has received much attention in hybrid applications because of its self-excitation capability, leading to a high power factor and high efficiency operation [6].

Various possible combinations of hybrid PMSG–PV systems are illustrated in the literature. Earlier, a six-arm converter topology was attempted, in which the outputs of a PV array and wind generator were subjected to a boost operation through individual switches to match the dc bus voltage [7]. In [8], a hybrid wind-PV system along with a battery was explained, in which both sources were connected to a common dc bus through individual power converters, and then, the dc bus was connected to the utility grid through an inverter. A grid connected PMSG–PV hybrid system with a battery backup was described in [9], where the dc-link voltage was fixed to the battery voltage, but the maximum power extraction from the wind-driven PMSG was not performed. A grid-connected hybrid system where the PV array and wind-driven PMSG were connected to a common dc link through a multi-input dc–dc converter was proposed earlier in [10]. In [11] a single-phase grid connected hybrid PMSG–PV array where the PV array is directly connected to DC link is proposed. An uncontrolled diode bridge rectifier followed by DC–DC converter and single-phase inverter are used and the DC-link voltage is tracked based on the duty cycle variation of DC–DC converter. But in this doesn't extract the maximum power from the wind. In all of the aforementioned

hybrid DG systems with PMSG–PV attempted so far, the system had either individual power converters for each of the sources or a battery backup. Furthermore, each converter was controlled using complex algorithms for peak power tracking. In order to minimize the conduction and switching losses of the devices, it is necessary to have the minimum number of power converters (power conversion stages), and this paper attempts for a system schema with minimum converters where three-phase voltage-source converter (VSC) is used on either side of the DC link. The proposed control scheme performs active maximum power transfer, DC-link voltage regulation, load compensation, and reduces torque pulsations in PMSG simultaneously. MPPT is employed for both PMSG and PV system And PV array being directly connected to the dc link instead of being connected through a dc–dc converter.

The remaining of this paper is organized as follows: Section 2 presents the system configuration and Simulation results and discussion of the proposed control scheme are provided in Sections 3 respectively. Finally, in Section 4, conclusions are drawn.

## II. DESCRIPTION OF THE SCHEME

The block diagram of the proposed DG scheme is given in Fig. 1, where a direct-driven PMSG and a PV array are the sources. A WSC is connected to the stator of PMSG and GSC transfers' power from the DG sources to the grid. Both WSC and GSC are bidirectional voltage source converters connected in back-to-back configuration through a common DC link. The PV array is tied to the DC bus creating a variable DC-link Voltage. To facilitate power extraction from both PV array and wind, the GSC is current controlled to deliver maximum power from both renewables. The DC voltage of the WSC is regulated to the MPP voltage of the PV array. The maximum power for the given irradiation and for the available wind speed/velocity is drawn by the action of the current controller developed for the GSC. The maximum power information from the hybrid DG sources is given to the GSC for generating reference grid currents at unity power factor (UPF). In this proposed scheme, the DC voltage reference for the WSC is set to the MPP voltage of the PV panel. In the absence of solar energy, the reference DC voltage of WSC is set to a default value.

### i. MPPT for wind

A maximum power point algorithm uses for maximum efficiency control and a maximum torque control to get the turbine output power maximum [12]. Based on the selected turbine characteristics, the relationship between the optimum generator torque and the generator speed is calculated. The behavior of the maximum torque control is determined by

$$T_{opt} = K_{opt} * w^2 \quad (1)$$

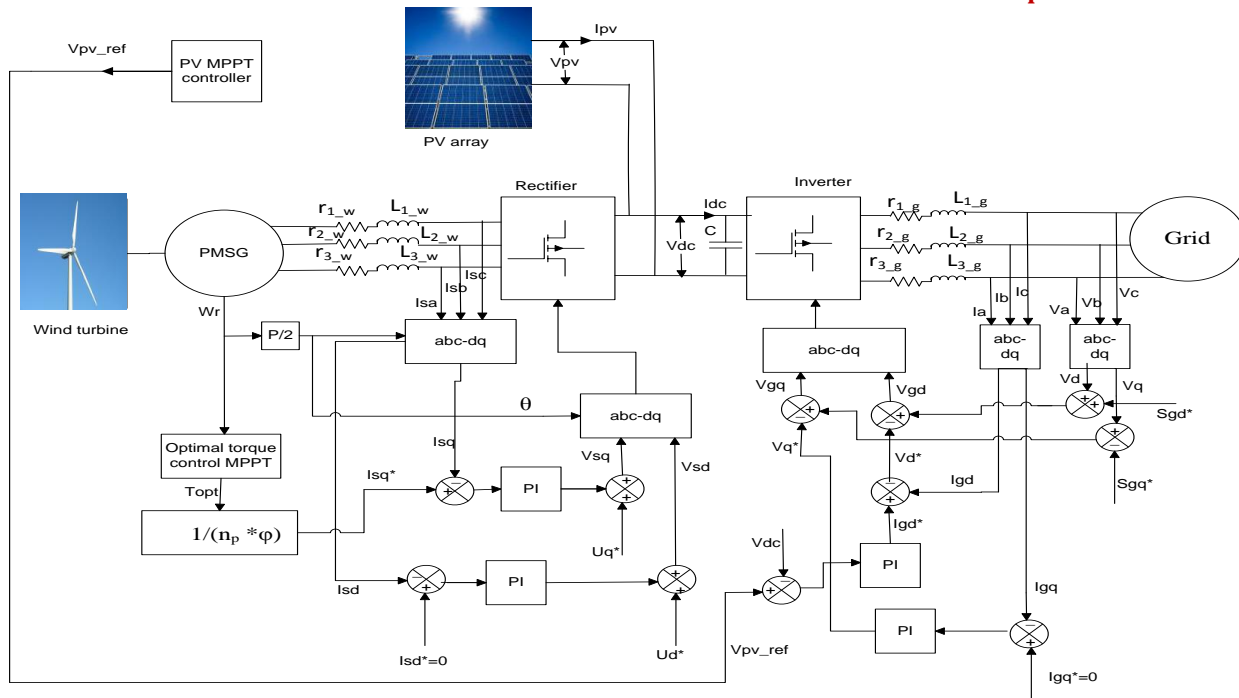

Fig.1Block diagram of proposed PV-wind grid connected system

ii. MPPT for PV

HCS method of MPPT [13] makes use of the inverted U shaped graph between power and voltage. As there is a definite peak power corresponding to a particular voltage, the algorithm compares the present power at an instant to the power obtained at the previous step. If the power is found to be increasing, then the duty cycle of the gating pulse applied to the converter switches are increased to drive the operating point more towards the peak power. If the power is found to be decreasing, then the duty cycle is reduced.

$$\delta_{new} = \delta_{old} + \text{sgn}(\Delta P)\text{sgn}(\Delta V)\Delta\delta \quad (2)$$

iii. WSC controller

The dynamic model of surface mounted PMSG is in (2- 4) which is represented by synchronous reference frame [14]

$$V_{sd} = R_s i_{sd} + L_d \frac{di_{sd}}{dt} + U_d^* \quad (3)$$

$$V_{sq} = R_s i_{sq} + L_q \frac{di_{sq}}{dt} + U_q^* \quad (4)$$

The q axis reference current is the torque controlling component and is given

$$i_{sq}^* = \frac{2 T_{ref}}{3 n_p \phi} \quad (5)$$

To minimize the copper loss in stator and produce maximum torque, d-axis reference current is set to zero that is  $i_d^*=0$ . The error signal of two current loops is given to two separate current controllers and the signals from the same are converted into voltage reference for PWM using

$$U_d^* = W_r L_q i_{sq} \quad (6)$$

$$U_q^* = -W_r L_d i_{sd} + W_r \phi \quad (7)$$

iv. GSC Control

The grid side converter is vector controlled in grid voltage reference frame [15]. In grid voltage vector reference frame the dynamic model of the grid connection is given by

$$V_{gd} = R_{gd} i_{gd} + L \frac{di_{gd}}{dt} + S_{gd}^* + V_d \quad (8)$$

$$V_{gq} = R i_{gq} + L \frac{di_{gq}}{dt} + S_{gq}^* + V_q \quad (9)$$

The block diagram of the grid side converter control scheme is shown in Fig. 4. Active and reactive power control is achieved by controlling direct and quadrature current components respectively. Two control loops are used to control the active and reactive power. An outer dc voltage control loop is used to set the d-axis current reference for active power control. This assures that all the power coming from the rectifier is instantaneously transferred to the grid by the inverter. The second channel controls the reactive power by setting a q-axis current reference to a current control loop similar to the previous one. The current controllers provide a voltage reference for the inverter that is compensated by adding rotational emf compensation terms

$$S_{gq}^* = W L i_{gq} \quad (10)$$

$$S_{gq}^* = W L i_{gd} \quad (11)$$

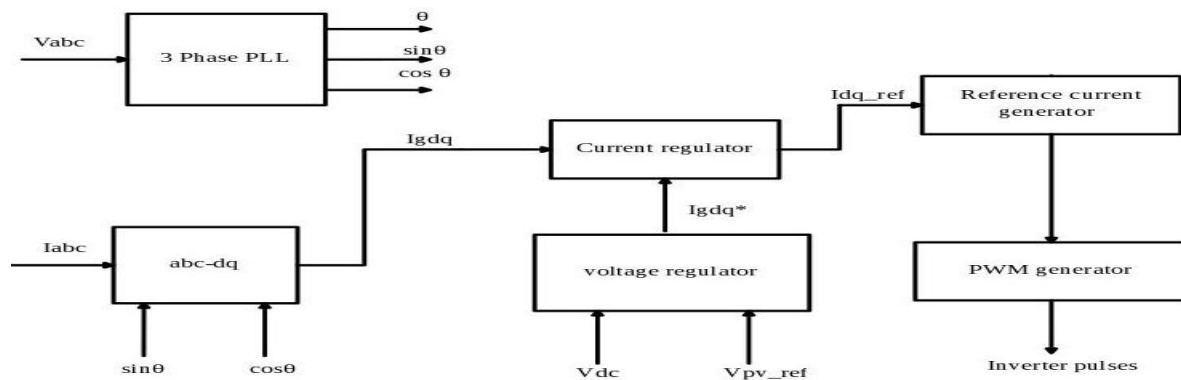

Fig.2 field oriented control algorithm for GSC

### III. DISCUSSION ON SIMULATION RESULTS

*i. Case 1 (both wind and PV generating power)*

When wind and PV power is available, the solar MPPT continuously tracks the maximum panel voltage value which is set as the reference voltage  $V_{pv\_ref}$  for the WSC. The output DC voltage of WSC is regulated to  $V_{pv\_ref}$  by outer voltage loop. By using the optimal torque control transfers this maximum power at PMSG to DC side. In order to make the GSC currents follow grid voltage along with maximum power transfer from both renewables, the reference currents for GSC are generated using vector control.

A wind speed of 12 m/s which makes PMSG to rotate at a speed of 122 rpm is considered. The PV array is subjected to an irradiation of 1000 W/m<sup>2</sup>. Figs. 3a and b show the compensated sinusoidal WSC currents and WSC voltages under constant wind speed, respectively. Fig. 3c implies UPF operation of WSC underrectification mode with power being transferred from PMSG to the DC side.

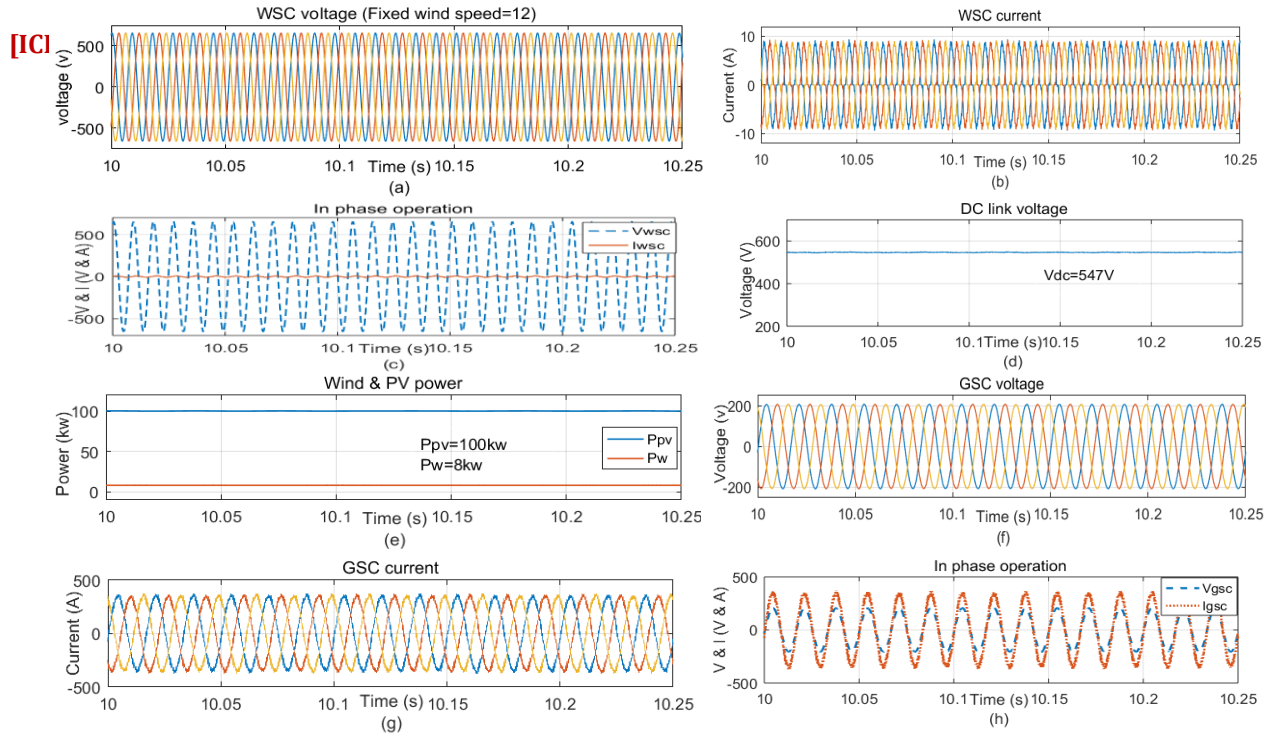

Fig.3. Simulation result for PV and wind delivers power to grid

Fig. 3d shows regulated DC-link Voltage (547) under constant wind and solar irradiation. Fig. 3e shows power lines of PMSG and PV. Figs. 3g and h show the utility grid voltage and GSC compensated grid currents. Figs. 3f shows UPF operation at grid

ii. Case 2 (wind generating power)

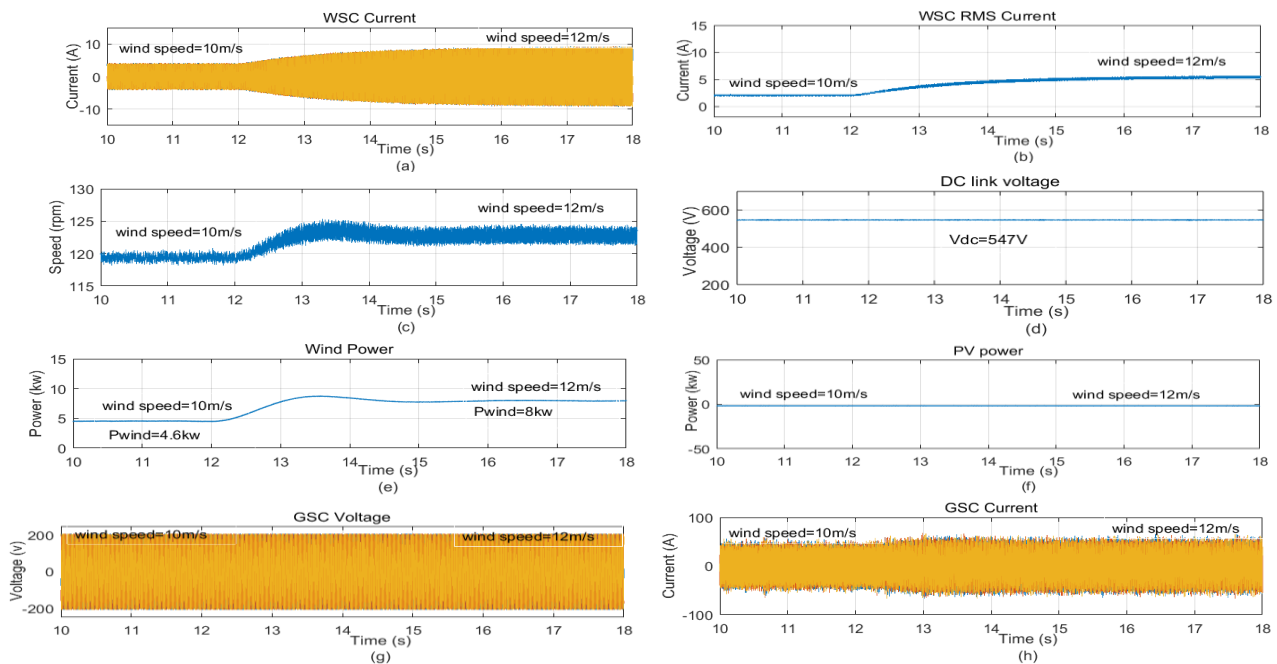

Fig.4. Simulation results for PV delivers power to grid

During night time or cloudy conditions when solar PV power cannot be extracted, MPPT algorithm becomes ineffective in generating  $V_{pv\_ref}$ . In such a case, the voltage controller regulates the DC-link voltage to 547 V and the power from the PMSG is transferred to the AC loads and grid by GSC. The wind speed variations (10–12 m/s) are investigated in SIMULINK environment, and the corresponding variations in WSC and GSC currents are shown in Fig. 4.

Fig. 4a and b show WSC current and WSC RMS current respectively for varying wind speed. Fig. 4c represent variable wind speed at  $t=12s$ . Fig. 4d shows regulated DC-link Voltage. Fig. 4e and f shows power lines of PMSG and PV. Figs. 4g and h show the utility grid voltage and GSC compensated grid currents.

*i. Case 3 (only PV generating power)*

Wind speed sometimes may reduce owing to climatic changes due to which, WSC may be unable to track the solar PV MPP voltage. With sun's irradiation varying over time in the absence of wind power, the PV power is directly fed to the DC link providing a variable link DC voltage. Consequently the compensated grid current also varies with varying illumination and temperature, thus transferring this variable power to the grid as shown in Fig. 5.

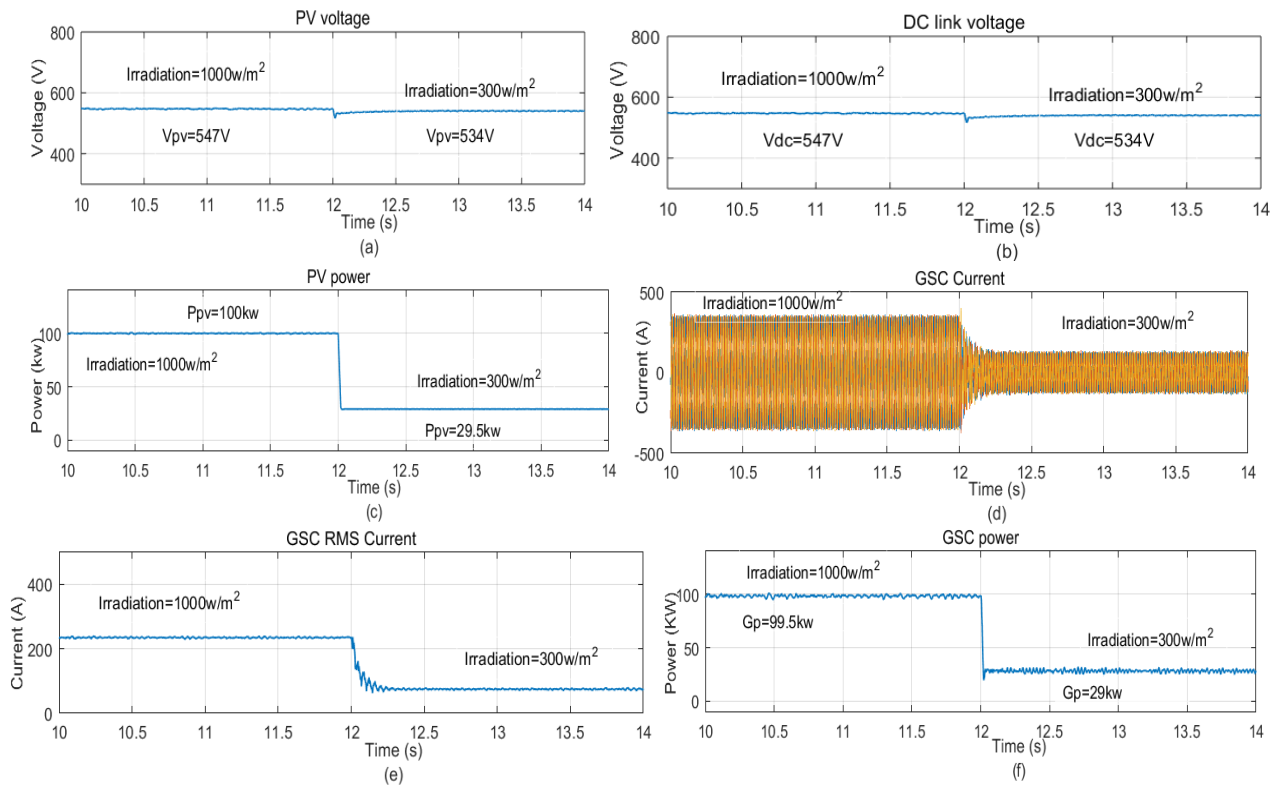

**Fig.5. Simulation result for wind delivers power to grid.**

Figs. 5a and b show DC-link voltage and PV power varying correspondingly to changes in illuminations introduced at  $t = 12$  s, respectively. Fig. 5c shows power lines of PV. Figs. 5d and e show GSC grid currents and GSC RMS value of grid reference current under varying irradiation, respectively. As irradiation varies from 1000 to 300 W/m<sup>2</sup>. Fig. 5f shows power at grid.

## ii. Case 4 (both wind and PV absent)

The fundamental reactive and harmonic VA needed for AC loads will be oscillating between the AC loads and capacitor through the GSC, whereas the total fundamental active power will be provided/ absorbed by the grid. In the absence of renewable power, the capacitor charges from grid. In the presence of renewable power, the capacitor is regulated to an MPP voltage of PV panel of by the action of PI controller. During both the modes of operation, the grid provides the active power required by the loads and the GSC compensates for the harmonic and oscillatory current of the loads.

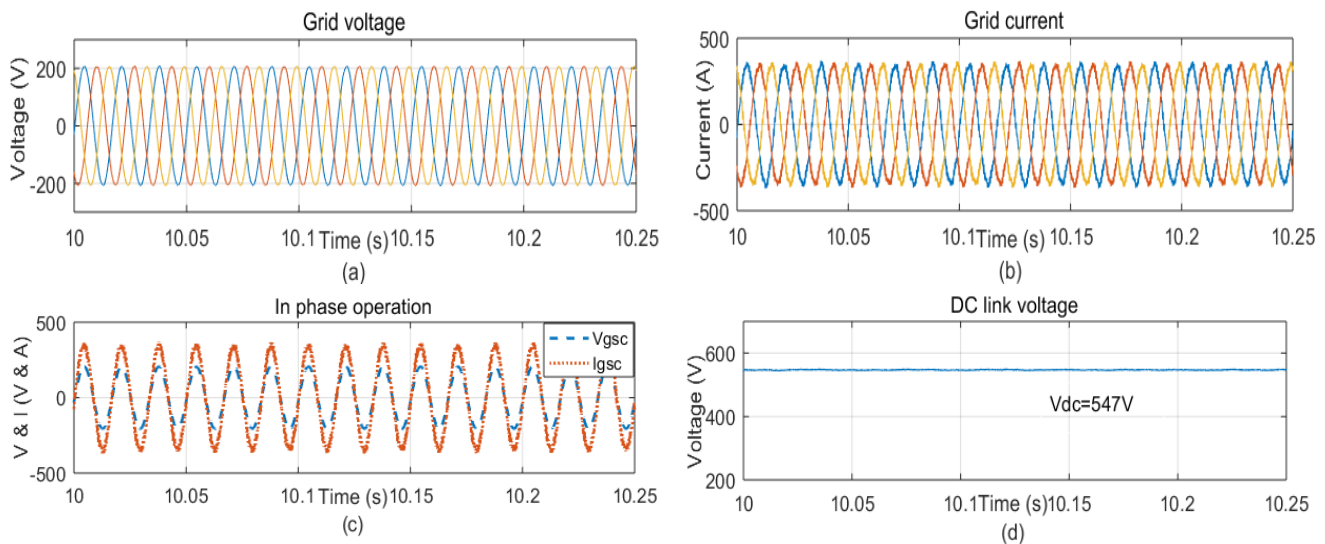

Fig.6. Simulation result for both wind and PV are absent

Figs. 6a and b show the grid side voltage and current when the renewable power available is sufficient enough to meet the power requirement of the load. Figs. 6c shows UPF operation at grid. Fig. 6d shows the regulated DC-link capacitance voltage.

#### IV. CONCLUSION

This paper presents a hybrid DG system comprising of PMSG based WECS and PV array system interfaced through a common DC link. With parallel operation of PMSG and PV, future expansion of the system becomes feasible allowing plug and play, load sharing and islanded mode of operation. The DC voltage is regulated to an MPP voltage of PV through WSC. Without involving any DC–DC converter and duty cycle variation and with fewer power converters employed, the system extracts maximum power from PMSG and PV and transfers it to linear/non-linear loads and grid through a GSC. Same VSC topology and controls is implemented in both WSC and GSC to achieve maximum power transfer under different resources and load conditions. The proposed system may facilitate the integration process of DC power technologies into the existing AC system.

#### REFERENCES

- [1] J. He, Y. W. Li, and F. Blaabjerg, "Flexible microgrid power quality enhancement using adaptive hybrid voltage and current controller," *IEEE Trans. Ind. Electron.*, vol. 61, no. 6, pp. 2784–2794, Jun. 2014.
- [2] W. Li, X. Ruan, C. Bao, D. Pan, and X. Wang, "Grid synchronization systems of three-phase grid-connected power converters: A complex vector-filter perspective," *IEEE Trans. Ind. Electron.*, vol. 61, no. 4, pp. 1855–1870, Apr. 2014.

- [3] C. Liu, K. T. Chau, and X. Zhang, "An efficient wind-photovoltaic hybrid generation system using doubly excited permanent-magnet brushless machine," *IEEE Trans. Ind. Electron.*, vol. 57, no. 3, pp. 831–839, Mar. 2010.
- [4] S. A. Daniel and N. A. Gounden, "A novel hybrid isolated generating system based on PV fed inverter-assisted wind-driven induction generators," *IEEE Trans. Energy Convers.*, vol. 19, no. 2, pp. 416–422, Jun. 2004.
- [5] H. Polinder, F. F. A. van der Pijl, G. J. de Vilder, and P. J. Tavner, "Comparison of direct-drive and geared generator concepts for wind turbines," *IEEE Trans. Energy Convers.*, vol. 21, no. 3, pp. 725–733, Sep. 2006.
- [6] T. F. Chan and L. L. Lai, "Permanent-magnet machines for distributed generation: A review," in *Proc. 2007 IEEE Power Engineering Annual Meeting*, pp. 1–6.
- [7] H. C. Chiang, T. T. Ma, Y. H. Cheng, J. M. Chang, and W. N. Chang, "Design and implementation of a hybrid regenerative power system combining grid-tie and uninterruptible power supply functions," *IET Renew. Power Gen.*, vol. 4, no. 1, pp. 85–99, 2010.
- [8] S.-K. Kim, J.-H. Jeon, C.-H. Cho, J.-B. Ahn, and S.-H. Kwon, "Dynamic modeling and control of a grid-connected hybrid generation system with versatile power transfer," *IEEE Trans. Ind. Electron.*, vol. 55, no. 4, pp. 1677–1688, Apr. 2008.
- [9] F. Giraud and Z. M. Salameh, "Steady-state performance of a gridconnected rooftop hybrid wind-photovoltaic power system with battery storage," *IEEE Trans. Energy Convers.*, vol. 16, no. 1, pp. 1–7, Mar. 2001.
- [10] S. Bae and A. Kwasinski, "Dynamic modeling and operation strategy for a microgrid with wind and photovoltaic resources," *IEEE Trans. SmartGrid*, vol. 3, no. 4, pp. 1867–1876, Dec. 2012.
- [11] Rajan Singaravel, M.M., Arul Daniel, S., "MPPT with single DC–DC converter and inverter for grid-connected hybrid wind-driven PMSG–PV array", *IEEE Trans. Ind. Electron.*, vol.62, no.8, pp. 4849–4857, 2015.
- [12] Kok Soon Tey, Saad Mekhilef "A Fast-converging MPPT Technique for Photovoltaic System under Fast Varying Solar Irradiation and Load Resistance", *IEEE Trans. Ind. Electron.*, vol. 11, pp. 176-186, 2014.
- [13] M.A. Abdullah., A.H.M. Yatim, C.W. Tan, et al.: "A review of maximum power point tracking algorithms for wind energy systems", *Renew. Sustainable Energy Rev.*, vol.16, no.5, pp. 3220–3227, 2012.
- [14] Chunxue Wen, Guojie Lu, Peng Wang, Zhengxi Li, Xu et al.: "Vector control strategy for small-scale grid connected PMSG wind turbine converter", *Innovative Smart Grid Technologies International Conference and Exhibition. Manchester, UK, Dec. 2011.*
- [15] Shuhui Li, Timothy A. Haskew, Yang-Ki Hong, Ling Xu "Direct-current vector control of three-phase grid-connected rectifier–inverter", *Electric Power Systems Research.*, 2011, pp. 357-366